



## QUAD CHANNEL HIGH SIDE SOLID STATE RELAY

TYPE	R <sub>DS(on)</sub> (*)	I <sub>lim</sub>	V <sub>CC</sub>
VNQ600A	35mΩ	25A	36 V

(\*) Per each channel

- DC SHORT CIRCUIT CURRENT: 25A
- CMOS COMPATIBLE INPUTS
- PROPORTIONAL LOAD CURRENT SENSE
- UNDERVOLTAGE & OVERVOLTAGE SHUT-DOWN
- OVERVOLTAGE CLAMP
- THERMAL SHUT-DOWN
- CURRENT LIMITATION
- VERY LOW STAND-BY POWER DISSIPATION
- PROTECTION AGAINST:
  - LOSS OF GROUND & LOSS OF V<sub>CC</sub>
- REVERSE BATTERY PROTECTION (\*\*)

### DESCRIPTION

The VNQ600A is a quad HSD formed by assembling two VND600 chips in the same SO-28

### ABSOLUTE MAXIMUM RATING

Symbol	Parameter	Value	Unit
V <sub>CC</sub>	Supply voltage (continuous)	41	V
-V <sub>CC</sub>	Reverse supply voltage (continuous)	-0.3	V
I <sub>OUT</sub>	Output current (continuous), for each channel	15	A
I <sub>R</sub>	Reverse output current (continuous), for each channel	-15	A
I <sub>IN</sub>	Input current	+/- 10	mA
V <sub>CSSENSE</sub>	Current sense maximum voltage	-3 +15	V V
I <sub>GND</sub>	Ground current at T <sub>pins</sub> ≤ 25°C (continuous)	-200	mA
V <sub>ESD</sub>	Electrostatic Discharge (Human Body Model: R=1.5KΩ; C=100pF)		
	- INPUT	4000	V
	- CURRENT SENSE	2000	V
	- OUTPUT	5000	V
	- V <sub>CC</sub>	5000	V
E <sub>MAX</sub>	Maximum Switching Energy (L=0.11mH; R <sub>L</sub> =0Ω; V <sub>bat</sub> =13.5V; T <sub>jstart</sub> =150°C; I <sub>L</sub> =40A)	126	mJ
P <sub>tot</sub>	Power dissipation (per island) at T <sub>lead</sub> =25°C	6.25	W
T <sub>j</sub>	Junction operating temperature	Internally Limited	°C
T <sub>stg</sub>	Storage temperature	-55 to 150	°C

(\*\*) See application schematic at page 9.

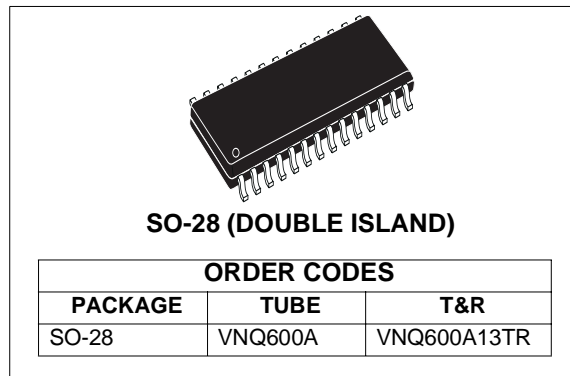

package. The VND600 is a monolithic device designed in STMicroelectronics VIPower M0-3 Technology. The VNQ600A is intended for driving any type of multiple loads with one side connected to ground. This device has four independent channels and four analog sense outputs which deliver currents proportional to the outputs currents. Active current limitation combined with thermal shut-down and automatic restart protect the device against overload. Device automatically turns off in case of ground pin disconnection.

BLOCK DIAGRAM

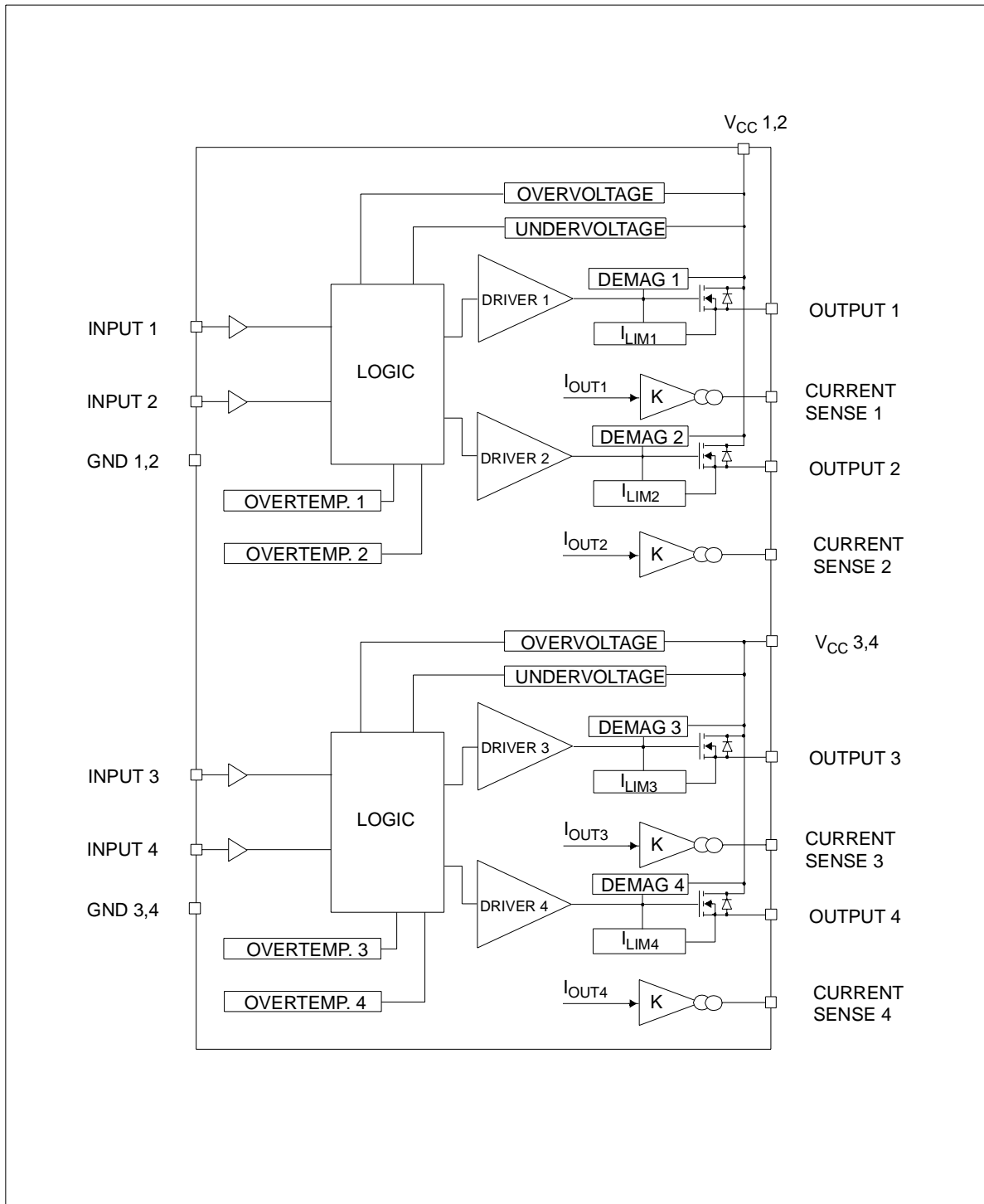

**CURRENT AND VOLTAGE CONVENTIONS**

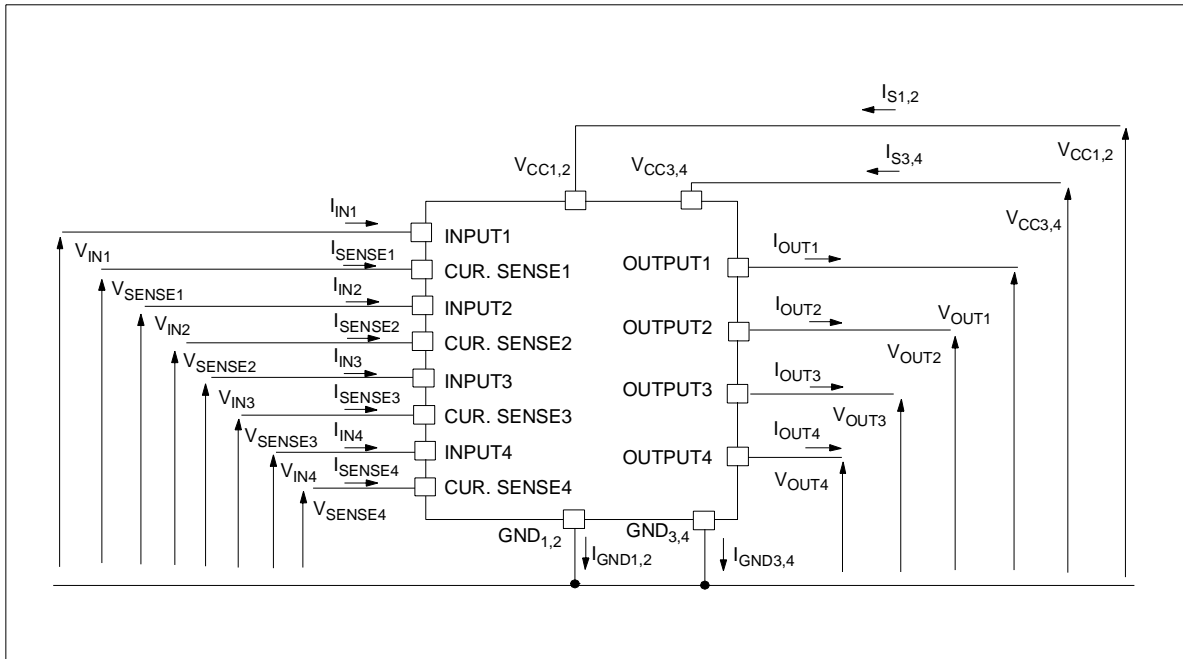

**CONNECTION DIAGRAM (TOP VIEW)**

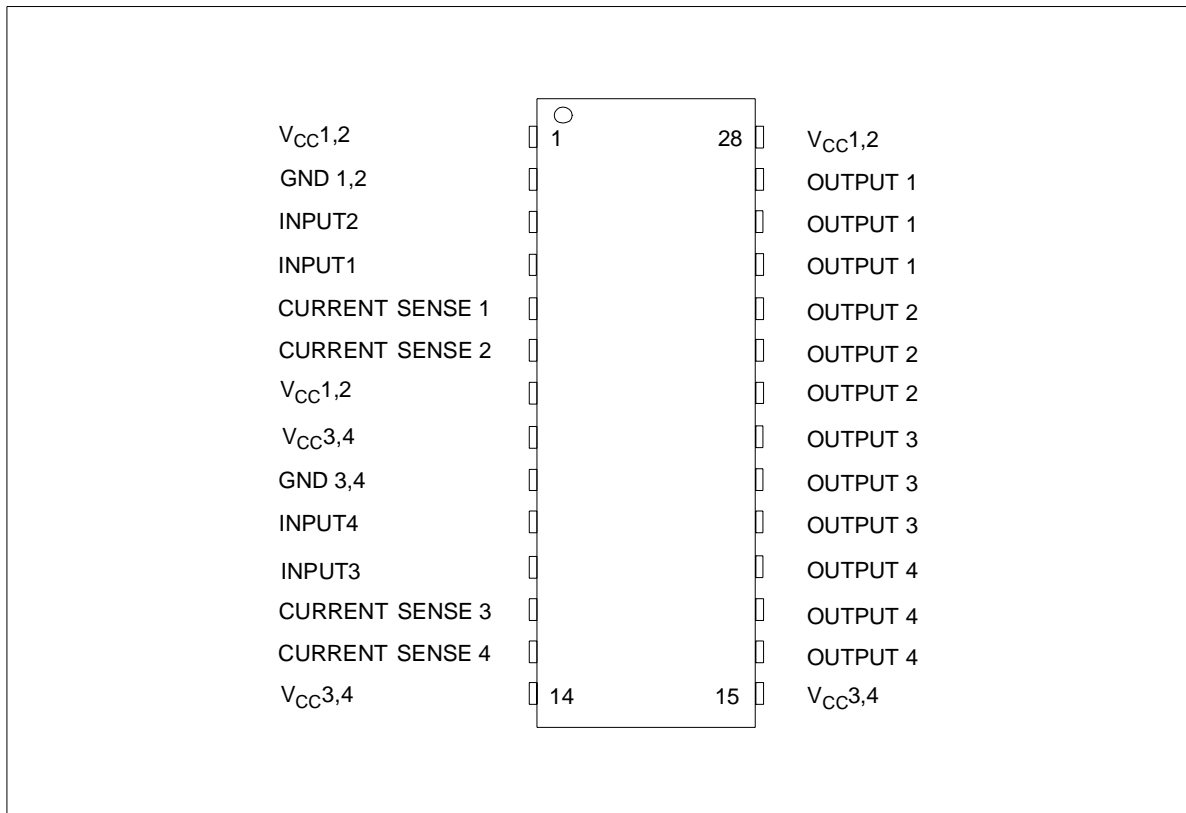

## VNQ600A

### THERMAL DATA (Per island)

Symbol	Parameter	Value	Unit
$R_{thj-lead}$	Thermal resistance Junction-lead	20	°C/W
$R_{thj-amb}$	Thermal resistance Junction-ambient (one chip ON)	60 (*)	°C/W
$R_{thj-amb}$	Thermal resistance Junction-ambient (two chips ON)	46 (*)	°C/W

(\*) When mounted on a standard single-sided FR-4 board with 0.5cm<sup>2</sup> of Cu (at least 35µm thick) connected to all V<sub>CC</sub> pins.  
Horizontal mounting and no artificial air flow.

### ELECTRICAL CHARACTERISTICS (8V < V<sub>CC</sub> < 36V; -40°C < T<sub>j</sub> < 150°C; unless otherwise specified)

(Per each channel)

#### POWER

Symbol	Parameter	Test Conditions	Min	Typ	Max	Unit
V <sub>CC</sub> (**)	Operating supply voltage		5.5	13	36	V
V <sub>USD</sub> (**)	Undervoltage shut-down		3	4	5.5	V
V <sub>OV</sub> (**)	Overvoltage shut-down		36			V
R <sub>ON</sub>	On state resistance	I <sub>OUT</sub> 1,2,3,4=5A; T <sub>j</sub> =25°C I <sub>OUT</sub> 1,2,3,4=5A; T <sub>j</sub> =150°C I <sub>OUT</sub> 1,2,3,4=3A; V <sub>CC</sub> =6V			35 70 120	mΩ mΩ mΩ
V <sub>clamp</sub>	Clamp Voltage	I <sub>CC</sub> =20mA (see note 1)	41	48	55	V
I <sub>S</sub> (**)	Supply current	Off State; V <sub>CC</sub> =13V; V <sub>IN</sub> =V <sub>OUT</sub> =0V Off State; V <sub>CC</sub> =13V; V <sub>IN</sub> =V <sub>OUT</sub> =0V; T <sub>j</sub> =25°C On State; V <sub>CC</sub> =13V; V <sub>IN</sub> =5V; I <sub>OUT</sub> =0A; R <sub>SENSE</sub> =3.9KΩ		12 12	40 25	µA µA
I <sub>L(off1)</sub>	Off state output current	V <sub>IN</sub> =V <sub>OUT</sub> =0V	0		50	µA
I <sub>L(off2)</sub>	Off State Output Current	V <sub>IN</sub> =0V; V <sub>OUT</sub> =3.5V	-75		0	µA
I <sub>L(off3)</sub>	Off State Output Current	V <sub>IN</sub> =V <sub>OUT</sub> =0V; V <sub>CC</sub> =13V; T <sub>j</sub> =125°C			5	µA
I <sub>L(off4)</sub>	Off State Output Current	V <sub>IN</sub> =V <sub>OUT</sub> =0V; V <sub>CC</sub> =13V; T <sub>j</sub> =25°C			3	µA

#### SWITCHING (V<sub>CC</sub>=13V)

Symbol	Parameter	Test Conditions	Min	Typ	Max	Unit
t <sub>D(on)</sub>	Turn-on delay time	R1=2.6Ω channels 1,2,3,4 (see fig. 1)		40		µs
t <sub>D(off)</sub>	Turn-off delay time	R1=2.6Ω channels 1,2,3,4 (see fig. 1)		40		µs
(dV <sub>OUT</sub> /dt) <sub>on</sub>	Turn-on voltage slope	R1=2.6Ω channels 1,2,3,4 (see fig. 1)		0.20		V/µs
(dV <sub>OUT</sub> /dt) <sub>off</sub>	Turn-off voltage slope	R1=2.6Ω channels 1,2,3,4 (see fig. 1)		0.20		V/µs

#### PROTECTIONS

Symbol	Parameter	Test Conditions	Min	Typ	Max	Unit
I <sub>lim</sub>	DC Short circuit current	V <sub>CC</sub> =13V 5.5V < V <sub>CC</sub> < 36V	25	40	70 70	A A
T <sub>TSD</sub>	Thermal shut-down temperature		150	175	200	°C
T <sub>R</sub>	Thermal reset temperature		135			°C
T <sub>hyst</sub>	Thermal hysteresis		7	15		°C
V <sub>demag</sub>	Turn-off output voltage clamp	I <sub>OUT</sub> =2A; L=6mH	V <sub>CC</sub> -41	V <sub>CC</sub> -48	V <sub>CC</sub> -55	V
V <sub>ON</sub>	Output voltage drop limitation	I <sub>OUT</sub> =0.5A; T <sub>j</sub> = -40°C...+150°C		50		mV

(\*\*) Per island

CURRENT SENSE ( $9V < V_{CC} < 16V$ ) (See Fig. 3)

Symbol	Parameter	Test Conditions	Min	Typ	Max	Unit
$K_1$	$I_{OUT}/I_{SENSE}$	$I_{OUT1,2}=0.35A$ ; $V_{SENSE}=0.5V$ ; $T_j = -40^{\circ}C...+150^{\circ}C$	3300	4350	6000	
$dK_1/K_1$	Current Sense Ratio Drift	$I_{OUT1}$ or $I_{OUT2}=0.5A$ ; $V_{SENSE}=0.5V$ ; other channels open; $T_j = -40^{\circ}C...+150^{\circ}C$	-10		+10	%
$K_2$	$I_{OUT}/I_{SENSE}$	$I_{OUT}=2A$ ; $V_{SENSE}=2.5V$ ; $T_j=-40^{\circ}C$ $T_j = 25^{\circ}C...+150^{\circ}C$	3900 4150	4850 4850	6000 5800	
$dK_2/K_2$	Current Sense Ratio Drift	$I_{OUT1}$ or $I_{OUT2}=5A$ ; $V_{SENSE}=4V$ ; other channels open; $T_j=-40^{\circ}C...+150^{\circ}C$	-6		+6	%
$K_3$	$I_{OUT}/I_{SENSE}$	$I_{OUT}=4A$ ; $V_{SENSE}=4V$ ; $T_j=-40^{\circ}C$ $T_j = 25^{\circ}C...+150^{\circ}C$	4150 4400	4900 4900	6000 5750	
$dK_3/K_3$	Current Sense Ratio Drift	$I_{OUT1}$ or $I_{OUT2}=15A$ ; $V_{SENSE}=4V$ ; other channels open; $T_j=-40^{\circ}C...+150^{\circ}C$	-6		+6	%
$V_{SENSE1,2}$	Max analog sense output voltage	$V_{CC}=5.5V$ ; $I_{OUT1,2}=2A$ ; $R_{SENSE}=10K\Omega$ $V_{CC}>8V$ ; $I_{OUT1,2}=4A$ ; $R_{SENSE}=10K\Omega$	2 4			V V
$V_{SENSEH}$	Analog sense output voltage in overtemperature condition	$V_{CC}=13V$ ; $R_{SENSE}=3.9K\Omega$		5		V
$R_{VSENSEH}$	Analog Sense Output Impedance in Overtemperature Condition	$V_{CC}=13V$ ; $T_j>T_{TSD}$ ; All channels open		400		$\Omega$
$t_{DSENSE}$	Current sense delay response	to 90% $I_{SENSE}$ (see note 2)			500	$\mu s$

## LOGIC INPUT

Symbol	Parameter	Test Conditions	Min	Typ	Max	Unit
$V_{IL}$	Low level input voltage				1.25	V
$V_{IH}$	High level input voltage		3.25			V
$V_{I(hyst)}$	Input hysteresis voltage		0.5			V
$I_{IL}$	Low level input current	$V_{IN}=1.25V$	20	65		$\mu A$
$I_{IH}$	High level input current	$V_{IN}=3.25V$		75	110	$\mu A$
$V_{ICL}$	Input clamp voltage	$I_{IN}=1mA$ $I_{IN}= -1mA$	6	6.8	8	V
				-0.7		V

Note 1:  $V_{clamp}$  and  $V_{OV}$  are correlated. Typical difference is 5V.

Note 2: current sense signal delay after positive input slope.

Note: Sense pin doesn't have to be left floating.

## TRUTH TABLE (per channel)

CONDITIONS	INPUT	OUTPUT	SENSE
Normal operation	L	L	0
	H	H	Nominal
Overtemperature	L	L	0
	H	L	$V_{SENSEH}$
Undervoltage	L	L	0
	H	L	0
Overvoltage	L	L	0
	H	L	0
Short circuit to GND	L	L	0
	H	L	$(T_j < T_{TSD}) 0$
	H	L	$(T_j > T_{TSD}) V_{SENSEH}$
Short circuit to $V_{CC}$	L	H	0
	H	H	< Nominal
Negative output voltage clamp	L	L	0

**ELECTRICAL TRANSIENT REQUIREMENTS**

ISO T/R 7637/1 Test Pulse	Test Levels I	Test Levels II	Test Levels III	Test Levels IV	Test Levels Delays and Impedance
1	-25V	-50V	-75V	-100V	2ms, 10Ω
2	+25V	+50V	+75V	+100V	0.2ms, 10Ω
3a	-25V	-50V	-100V	-150V	0.1μs, 50Ω
3b	+25V	+50V	+75V	+100V	0.1μs, 50Ω
4	-4V	-5V	-6V	-7V	100ms, 0.01Ω
5	+26.5V	+46.5V	+66.5V	+86.5V	400ms, 2Ω

ISO T/R 7637/1 Test Pulse	Test Levels Result I	Test Levels Result II	Test Levels Result III	Test Levels Result IV
1	C	C	C	C
2	C	C	C	C
3a	C	C	C	C
3b	C	C	C	C
4	C	C	C	C
5	C	E	E	E

Class	Contents
C	All functions of the device are performed as designed after exposure to disturbance.
E	One or more functions of the device is not performed as designed after exposure and cannot be returned to proper operation without replacing the device.

**Figure 1:** Switching Characteristics (Resistive load  $R_L=2.6\Omega$ )

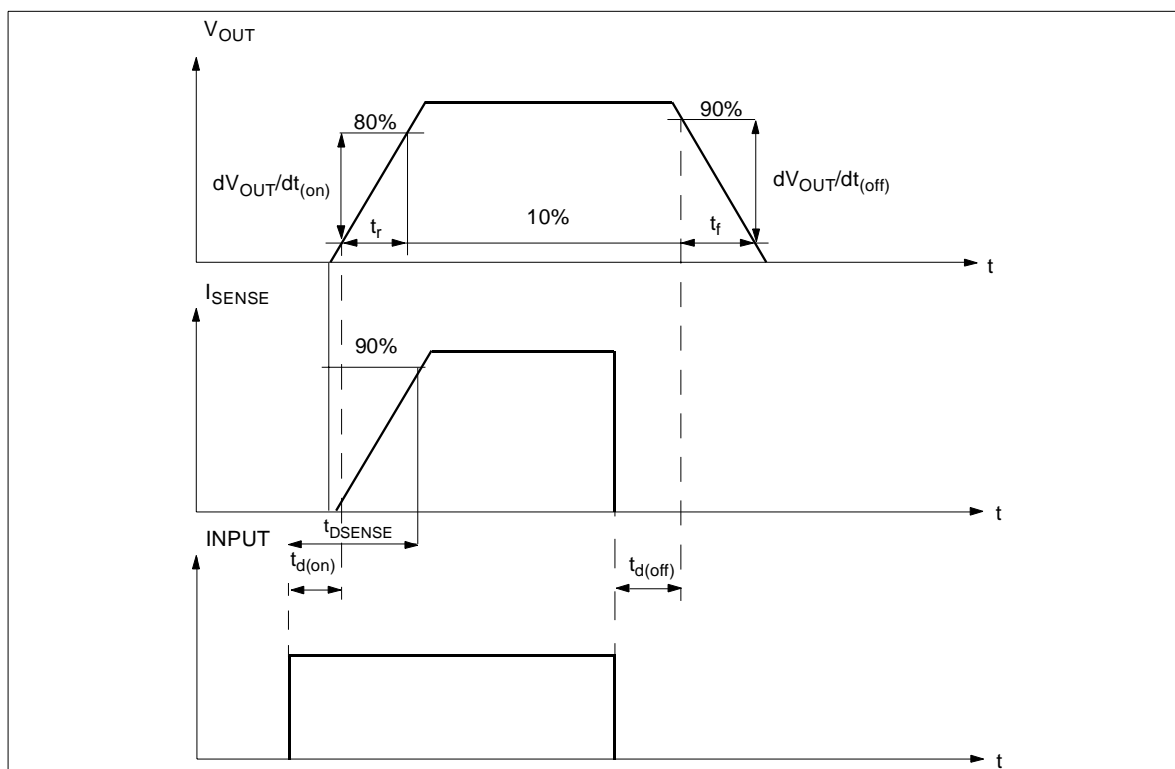
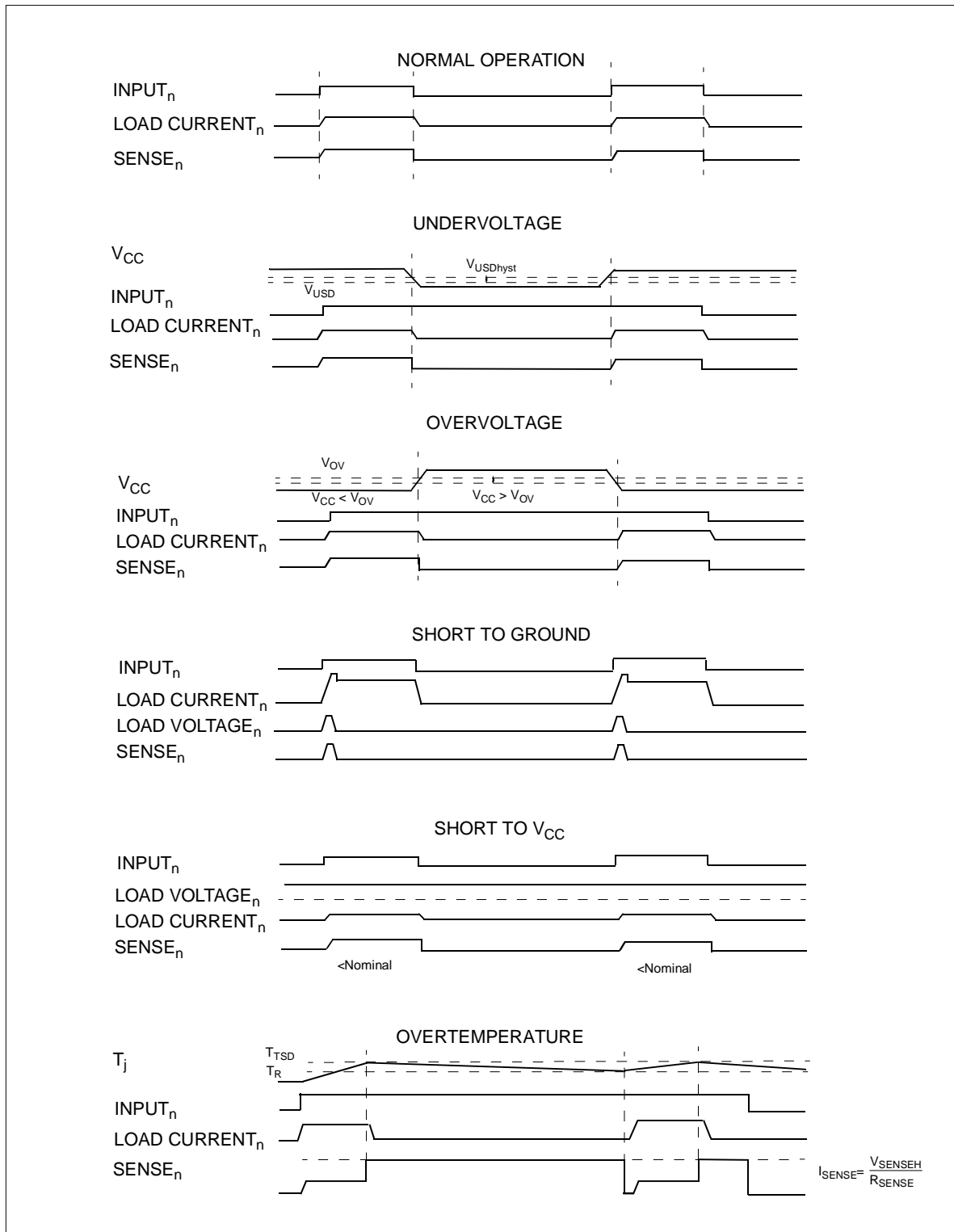
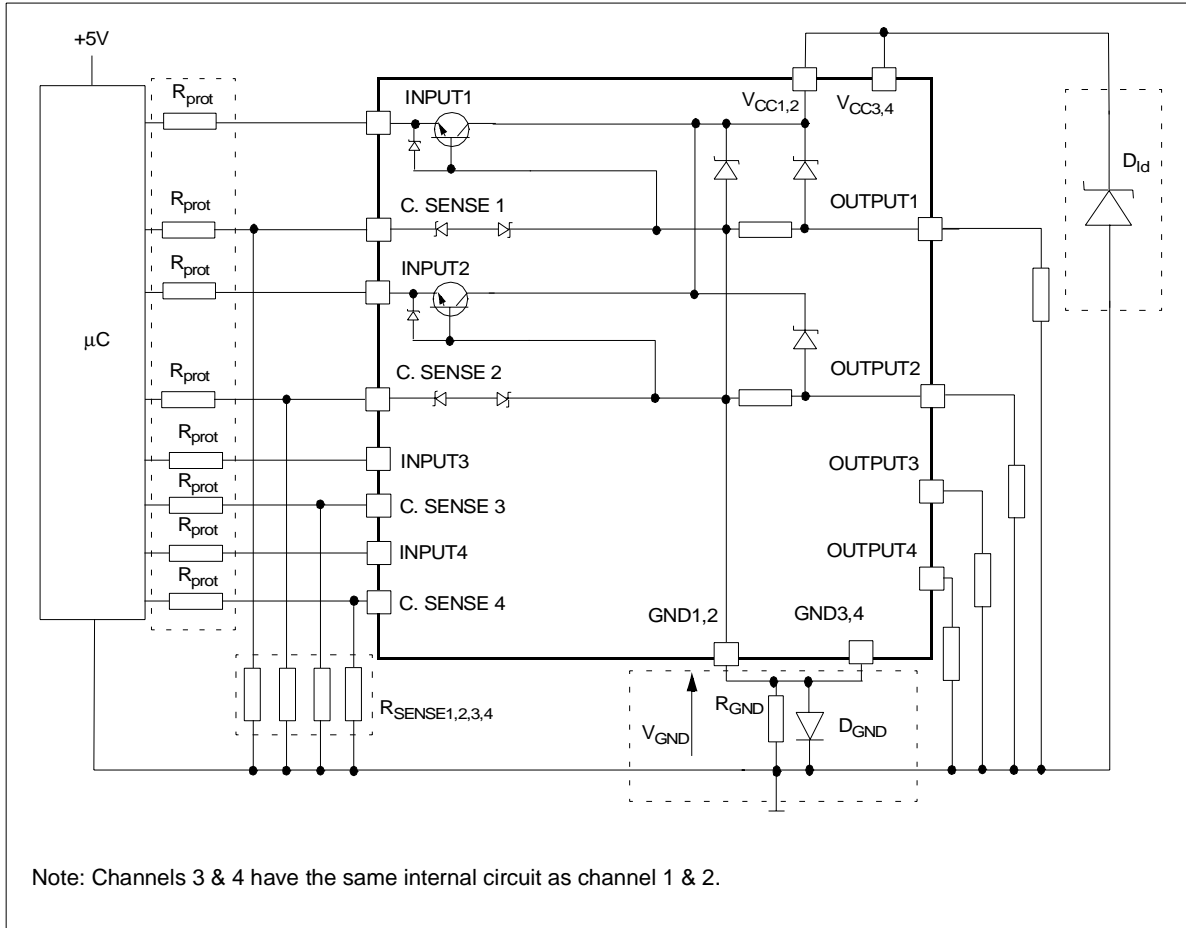

Figure 2: Waveforms (per each chip)





APPLICATION SCHEMATIC



**GND PROTECTION NETWORK AGAINST REVERSE BATTERY**

**Solution 1:** Resistor in the ground line ( $R_{GND}$  only). This can be used with any type of load.

The following is an indication on how to dimension the  $R_{GND}$  resistor.

$$1) R_{GND} \leq 600mV / 2(I_{S(on)max})$$

$$2) R_{GND} \geq (-V_{CC}) / (-I_{GND})$$

where  $-I_{GND}$  is the DC reverse ground pin current and can be found in the absolute maximum rating section of the device's datasheet.

Power Dissipation in  $R_{GND}$  (when  $V_{CC} < 0$ : during reverse battery situations) is:

$$P_D = (-V_{CC})^2 / R_{GND}$$

This resistor can be shared amongst several different HSD. Please note that the value of this resistor should be calculated with formula (1) where  $I_{S(on)max}$  becomes the sum of the maximum on-state currents of the different devices.

Please note that if the microprocessor ground is not common with the device ground then the  $R_{GND}$  will produce a shift ( $I_{S(on)max} * R_{GND}$ ) in the input thresholds

and the status output values. This shift will vary depending on how many devices are ON in the case of several high side drivers sharing the same  $R_{GND}$ .

If the calculated power dissipation leads to a large resistor or several devices have to share the same resistor then the ST suggests to utilize Solution 2 (see below).

**Solution 2:** A diode ( $D_{GND}$ ) in the ground line.

A resistor ( $R_{GND} = 1k\Omega$ ) should be inserted in parallel to  $D_{GND}$  if the device will be driving an inductive load.

This small signal diode can be safely shared amongst several different HSD. Also in this case, the presence of the ground network will produce a shift ( $\approx 600mV$ ) in the input threshold and the status output values if the microprocessor ground is not common with the device ground. This shift will not vary if more than one HSD shares the same diode/resistor network.

**LOAD DUMP PROTECTION**

$D_{Id}$  is necessary (Voltage Transient Suppressor) if the load dump peak voltage exceeds  $V_{CC}$  max DC rating. The same applies if the device will be subject to transients on the  $V_{CC}$  line that are greater than the ones shown in the ISO T/R 7637/1 table.

**μC I/Os PROTECTION:**

If a ground protection network is used and negative transients are present on the V<sub>CC</sub> line, the control pins will be pulled negative. ST suggests to insert a resistor (R<sub>prot</sub>) in line to prevent the μC I/Os pins to latch-up.

The value of these resistors is a compromise between the leakage current of μC and the current required by the HSD I/Os (Input levels compatibility) with the latch-up limit of μC I/Os.

$$-V_{CCpeak}/I_{latchup} \leq R_{prot} \leq (V_{OH\mu C} - V_{IH} - V_{GND}) / I_{IHmax}$$

Calculation example:

For V<sub>CCpeak</sub> = -100V and I<sub>latchup</sub> ≥ 20mA; V<sub>OHμC</sub> ≥ 4.5V  
 5kΩ ≤ R<sub>prot</sub> ≤ 6kΩ.

Recommended R<sub>prot</sub> value is 5kΩ.

**Figure 3:** I<sub>OUT</sub>/I<sub>SENSE</sub> versus I<sub>OUT</sub>

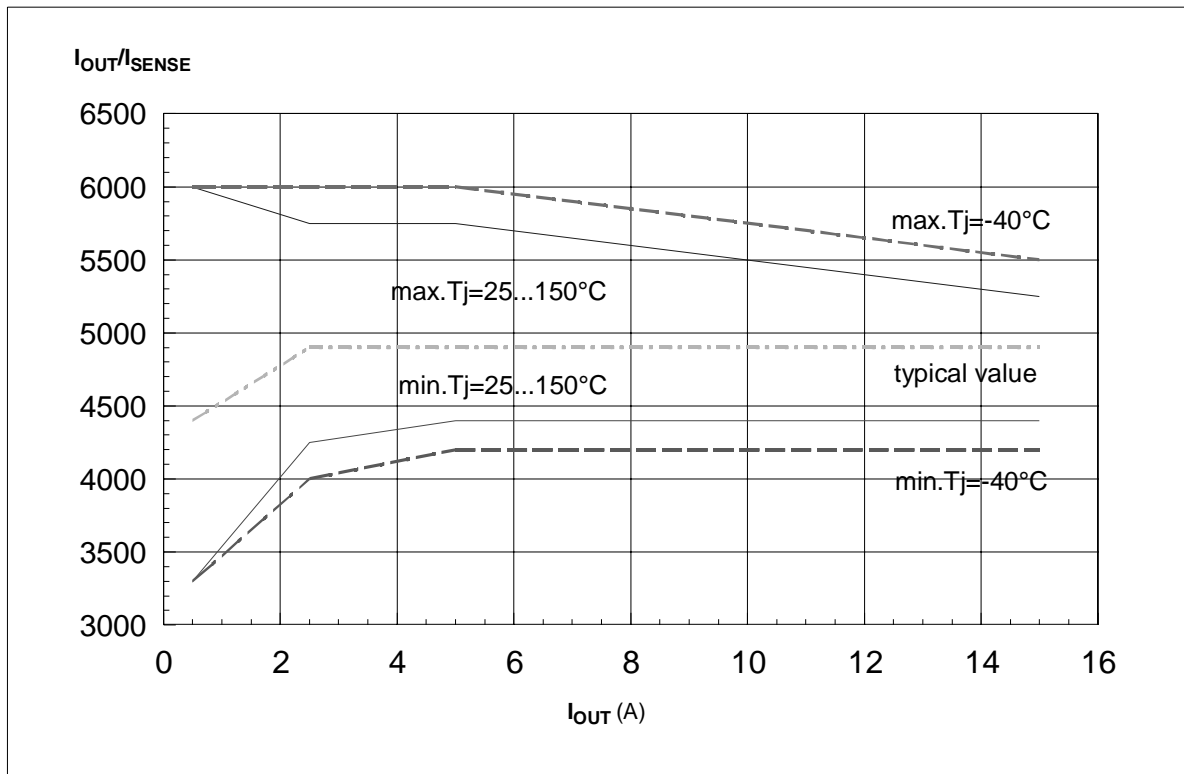

Off State Output Current

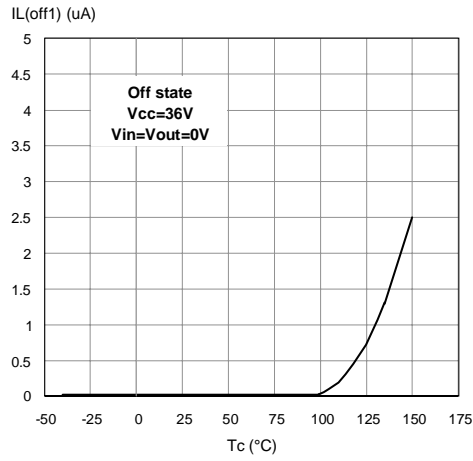

High Level Input Current

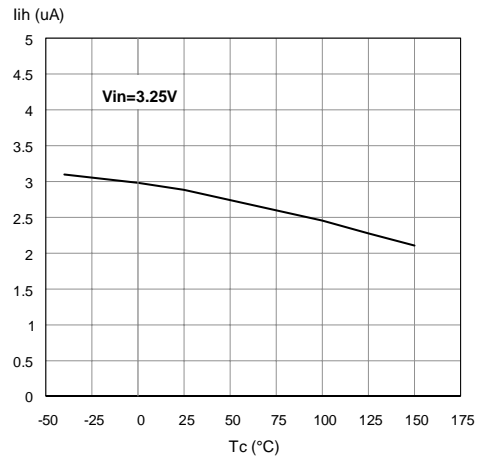

Input Clamp Voltage

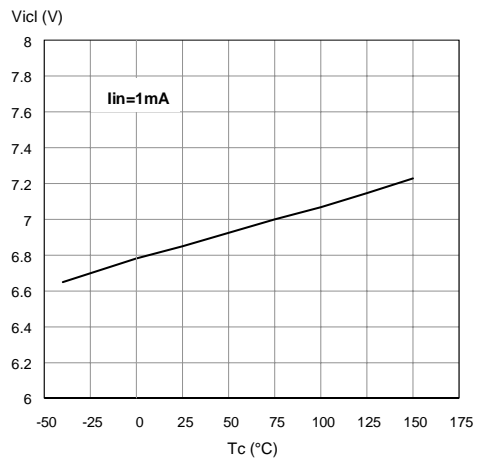

Input High Level

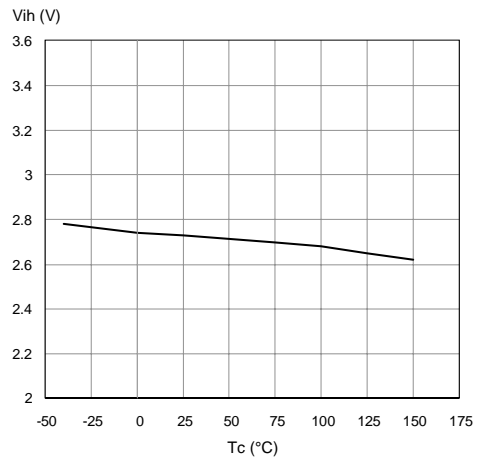

Input Low Level

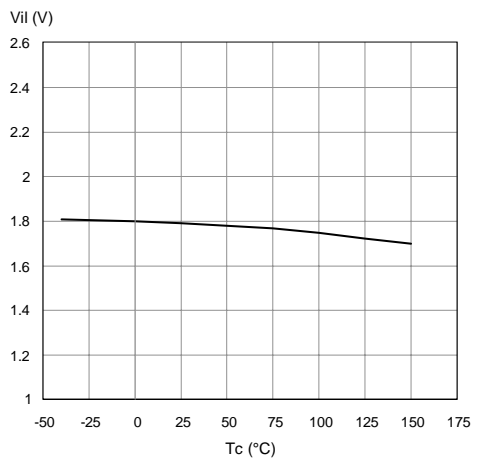

Input Hysteresis Voltage

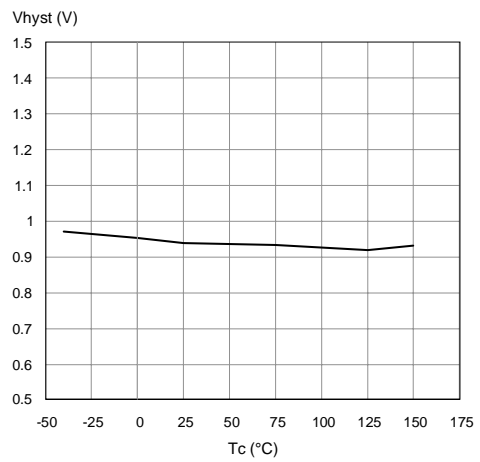

Overvoltage Shutdown

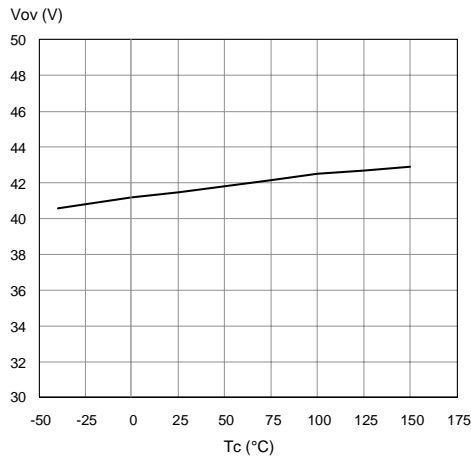

I<sub>LIM</sub> Vs T<sub>case</sub>

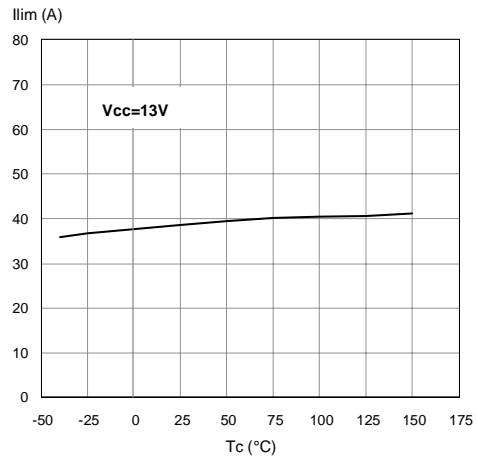

Turn-on Voltage Slope

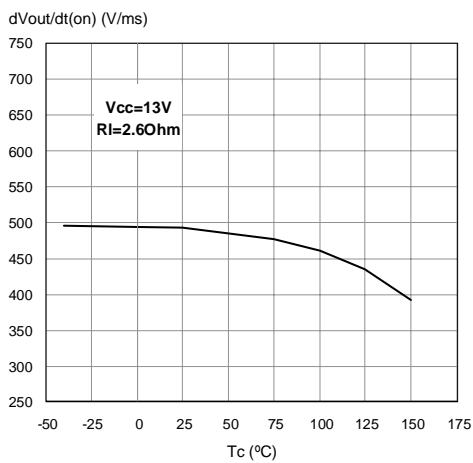

Turn-off Voltage Slope

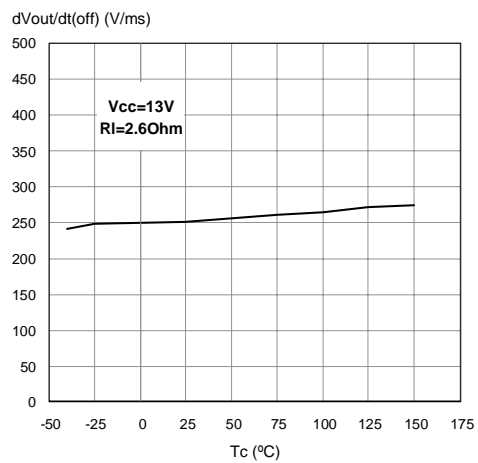

On State Resistance Vs T<sub>case</sub>

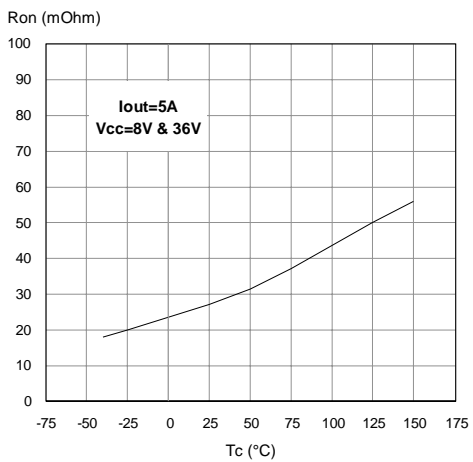

On State Resistance Vs V<sub>CC</sub>

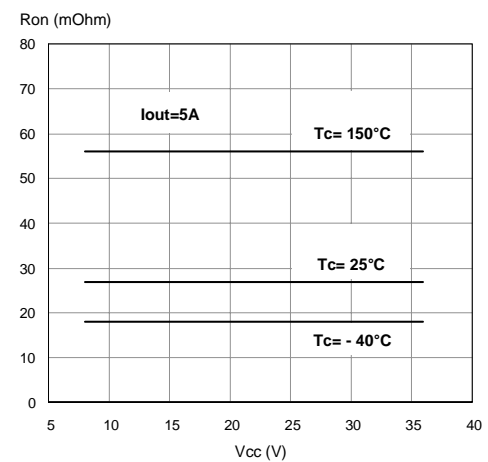

Maximum turn off current versus load inductance

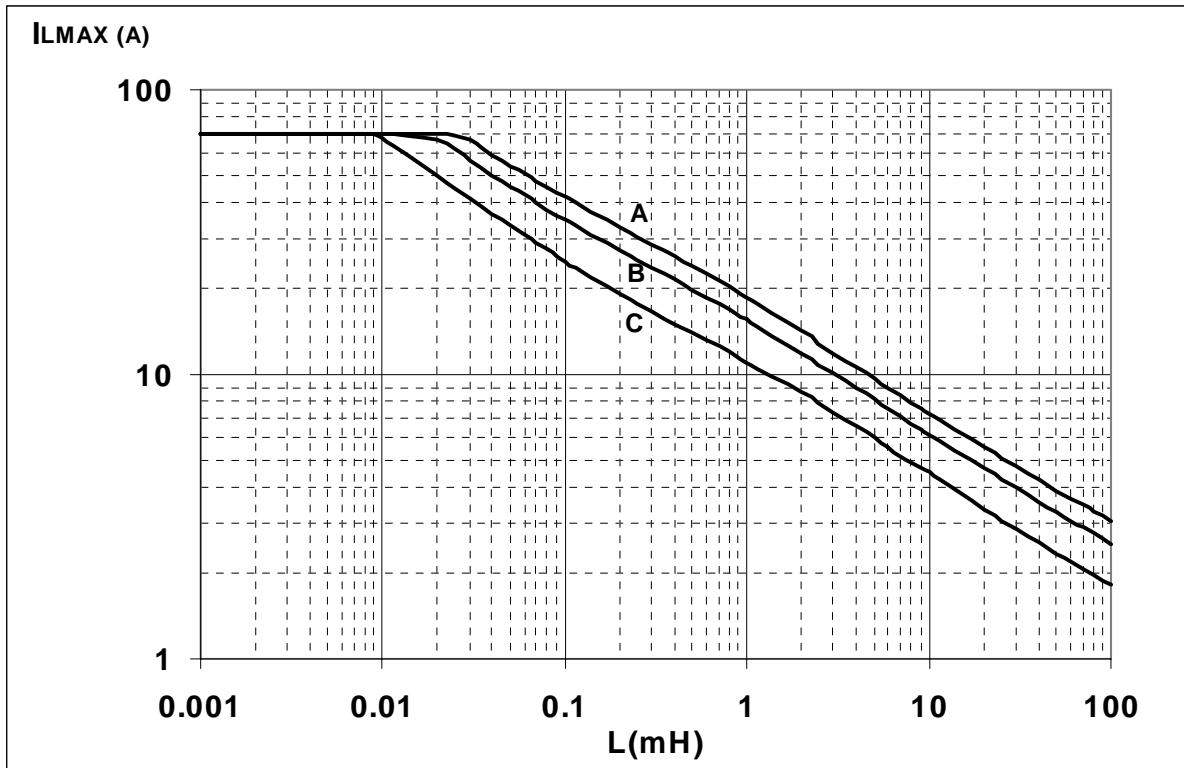

- A = Single Pulse at  $T_{jstart} = 150^\circ\text{C}$
- B = Repetitive pulse at  $T_{jstart} = 100^\circ\text{C}$
- C = Repetitive Pulse at  $T_{jstart} = 125^\circ\text{C}$

Conditions:

$V_{CC} = 13.5\text{V}$

Values are generated with  $R_L = 0\Omega$

In case of repetitive pulses,  $T_{jstart}$  (at beginning of each demagnetization) of every pulse must not exceed the temperature specified above for curves B and C.

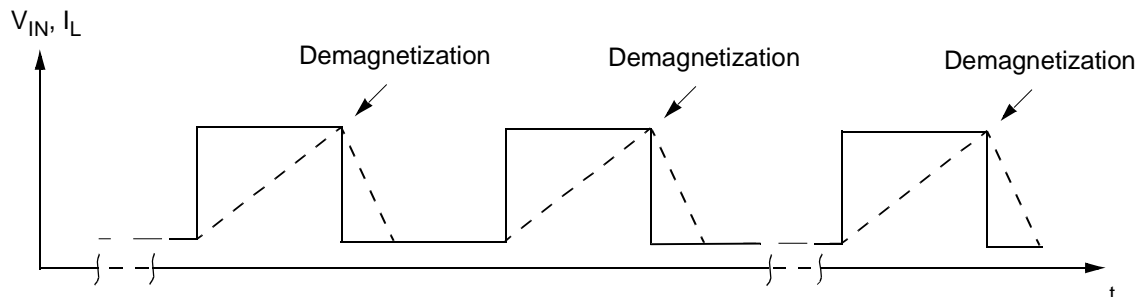

**SO-28 DOUBLE ISLAND THERMAL DATA**

**SO-28 Double island PC Board**

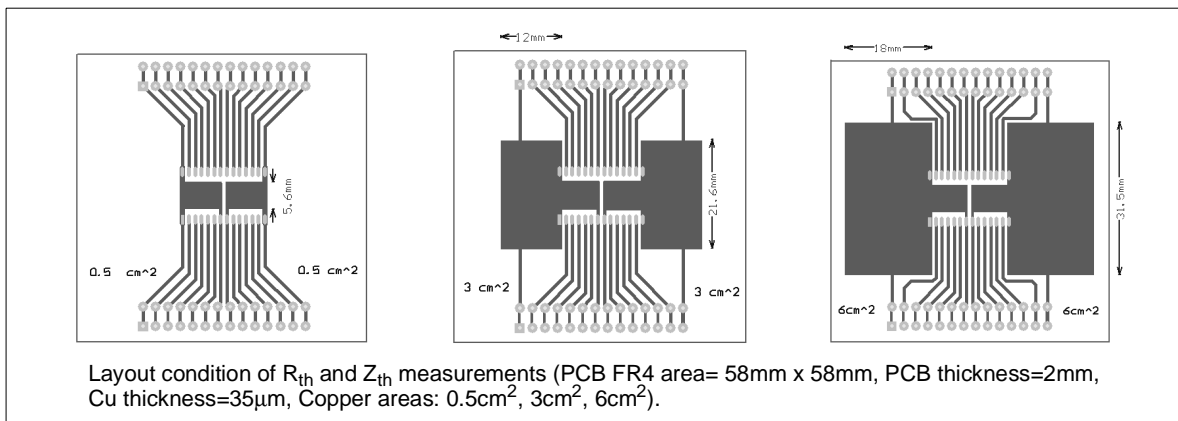

**Thermal calculation according to the PCB heatsink area**

Chip 1	Chip 2	$T_{jchip1}$	$T_{jchip2}$	Note
ON	OFF	$R_{thA} \times P_{dchip1} + T_{amb}$	$R_{thC} \times P_{dchip1} + T_{amb}$	
OFF	ON	$R_{thC} \times P_{dchip2} + T_{amb}$	$R_{thA} \times P_{dchip2} + T_{amb}$	
ON	ON	$R_{thB} \times (P_{dchip1} + P_{dchip2}) + T_{amb}$	$R_{thB} \times (P_{dchip1} + P_{dchip2}) + T_{amb}$	$P_{dchip1} = P_{dchip2}$
ON	ON	$(R_{thA} \times P_{dchip1}) + R_{thC} \times P_{dchip2} + T_{amb}$	$(R_{thA} \times P_{dchip2}) + R_{thC} \times P_{dchip1} + T_{amb}$	$P_{dchip1} \neq P_{dchip2}$

$R_{thA}$  = Thermal resistance Junction to Ambient with one chip ON  
 $R_{thB}$  = Thermal resistance Junction to Ambient with both chips ON and  $P_{dchip1} = P_{dchip2}$   
 $R_{thC}$  = Mutual thermal resistance

**$R_{thj-amb}$  Vs PCB copper area in open box free air condition**

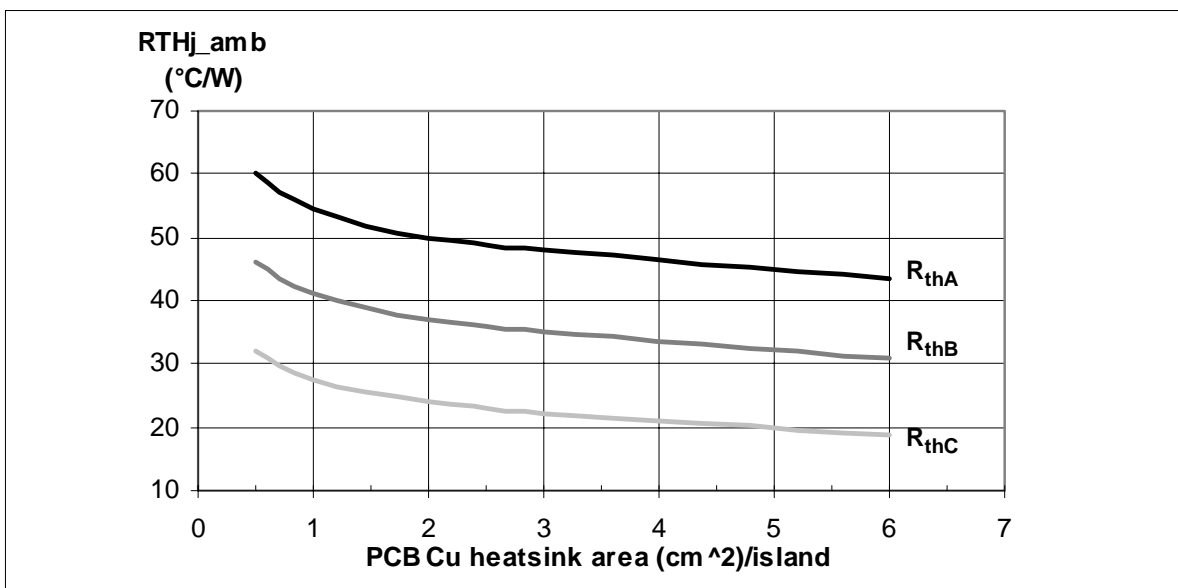

SO-28 Thermal Impedance Junction Ambient Single Pulse

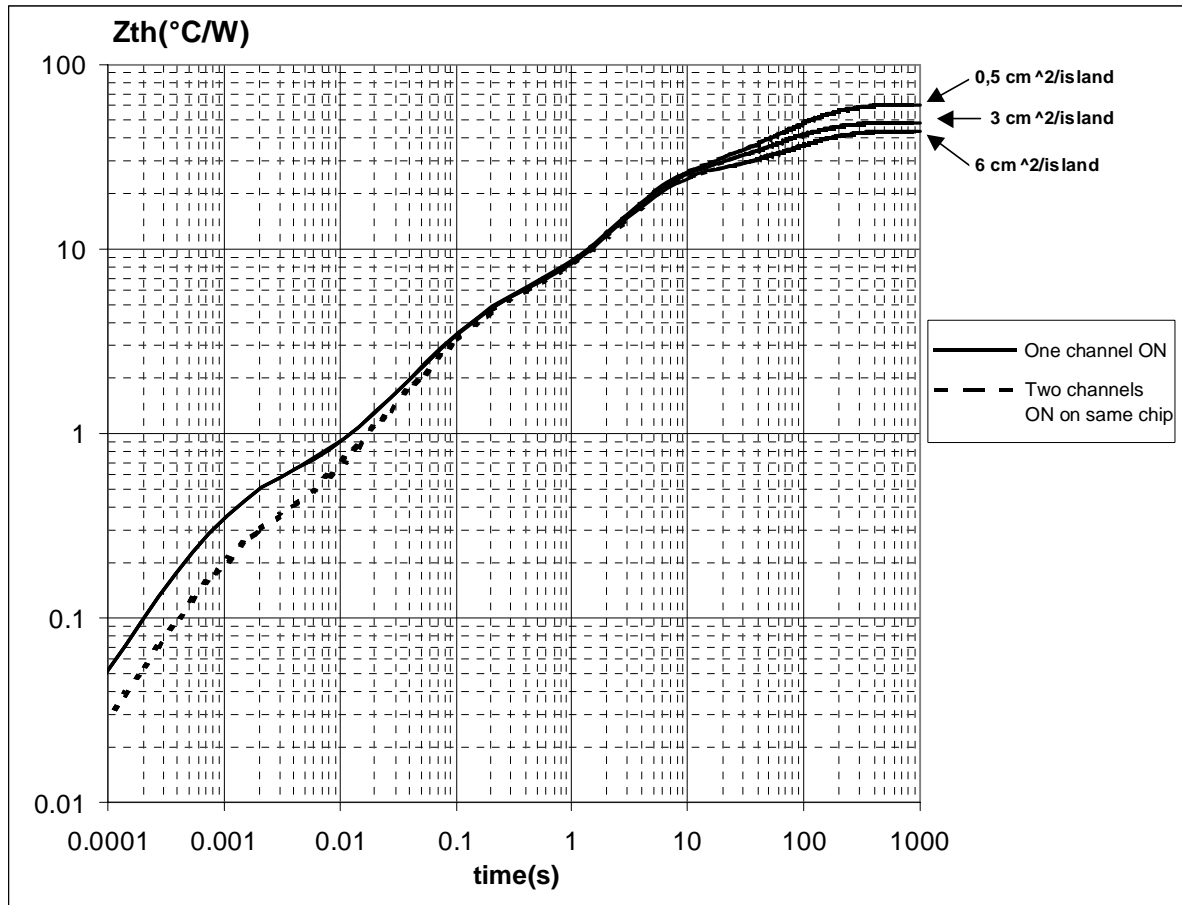

Thermal fitting model of a four channels HSD in SO-28

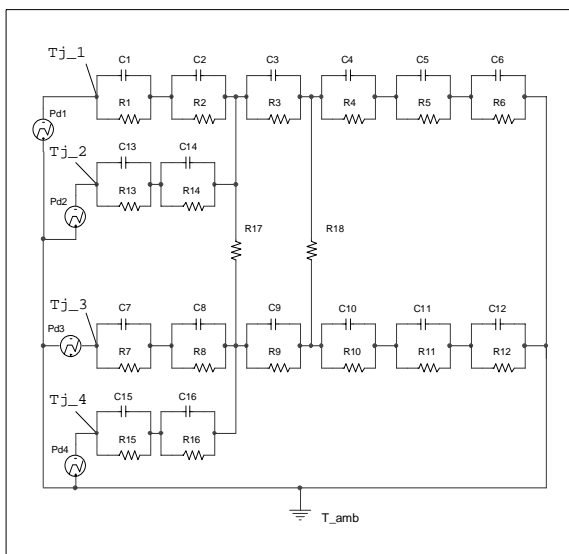

Pulse calculation formula

$$Z_{TH\delta} = R_{TH} \cdot \delta + Z_{THtp}(1 - \delta)$$

where  $\delta = t_p / T$

Thermal Parameter

Area/island (cm <sup>2</sup> )	0.5	6
R1=R7=R13=R15 (°C/W)	0.05	
R2=R8=R14=R16 (°C/W)	0.3	
R3=R9 (°C/W)	3.4	
R4=R10 (°C/W)	11	
R5=R11 (°C/W)	15	
R6=R12 (°C/W)	30	13
C1=C7=C13=C15 (W.s/°C)	0.001	
C2=C8=C14=C16 (W.s/°C)	5.00E-03	
C3=C9 (W.s/°C)	1.00E-02	
C4=C10 (W.s/°C)	0.2	
C5=C11 (W.s/°C)	1.5	
C6=C12 (W.s/°C)	5	8
R17=R18 (°C/W)	150	

## SO-28 MECHANICAL DATA

DIM.	mm.			inch		
	MIN.	TYP	MAX.	MIN.	TYP.	MAX.
A			2.65			0.104
a1	0.10		0.30	0.004		0.012
b	0.35		0.49	0.013		0.019
b1	0.23		0.32	0.009		0.012
C		0.50			0.020	
c1	45 (typ.)					
D	17.7		18.1	0.697		0.713
E	10.00		10.65	0.393		0.419
e		1.27			0.050	
e3		16.51			0.650	
F	7.40		7.60	0.291		0.299
L	0.40		1.27	0.016		0.050
S	8 (max.)					

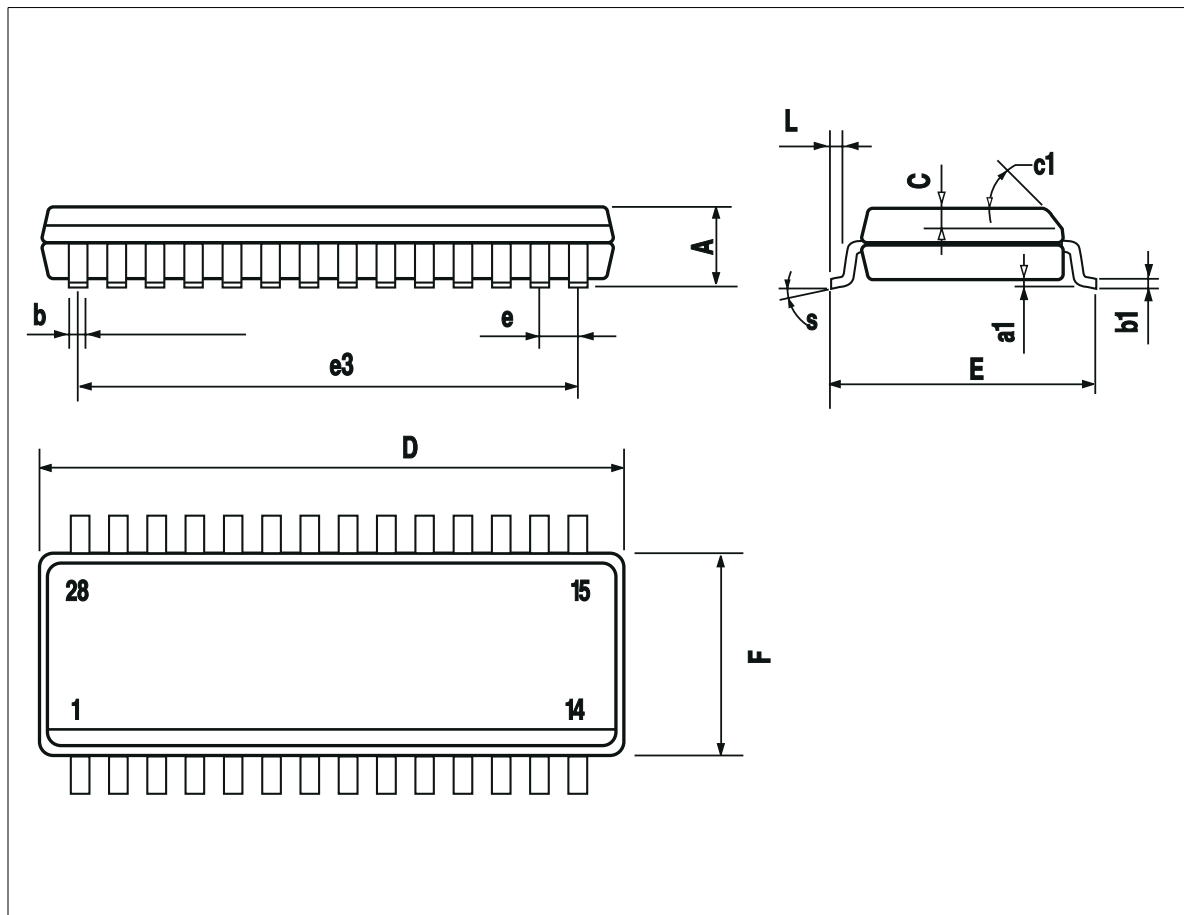



**SO-28 TUBE SHIPMENT (no suffix)**

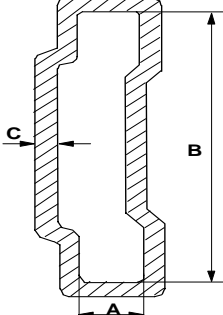

<b>Base Q.ty</b>	28
<b>Bulk Q.ty</b>	700
<b>Tube length (<math>\pm 0.5</math>)</b>	532
<b>A</b>	3.5
<b>B</b>	13.8
<b>C (<math>\pm 0.1</math>)</b>	0.6

All dimensions are in mm.

**TAPE AND REEL SHIPMENT (suffix "13TR")**

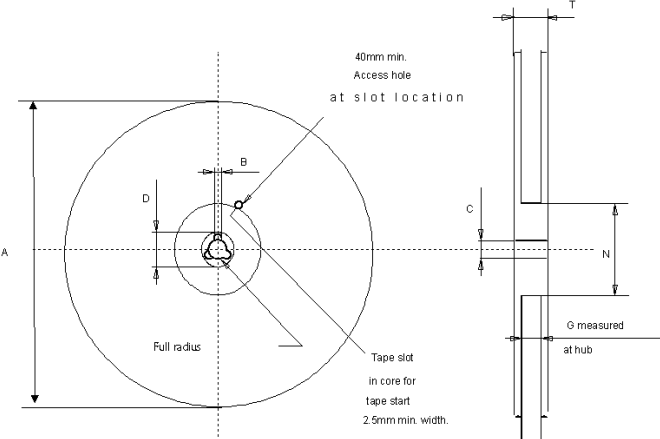

<b>Base Q.ty</b>	1000
<b>Bulk Q.ty</b>	1000
<b>A (max)</b>	330
<b>B (min)</b>	1.5
<b>C (<math>\pm 0.2</math>)</b>	13
<b>F</b>	20.2
<b>G (+ 2 / - 0)</b>	16.4
<b>N (min)</b>	60
<b>T (max)</b>	22.4

**TAPE DIMENSIONS**

According to Electronic Industries Association (EIA) Standard 481 rev. A, Feb 1986

<b>Tape width</b>	<b>W</b>	16
<b>Tape Hole Spacing</b>	<b>P0 (<math>\pm 0.1</math>)</b>	4
<b>Component Spacing</b>	<b>P</b>	12
<b>Hole Diameter</b>	<b>D (<math>\pm 0.1/-0</math>)</b>	1.5
<b>Hole Diameter</b>	<b>D1 (min)</b>	1.5
<b>Hole Position</b>	<b>F (<math>\pm 0.05</math>)</b>	7.5
<b>Compartment Depth</b>	<b>K (max)</b>	6.5
<b>Hole Spacing</b>	<b>P1 (<math>\pm 0.1</math>)</b>	2

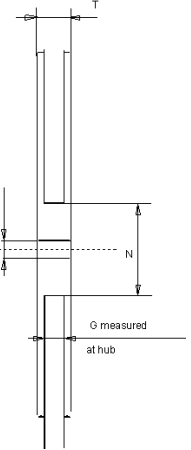

All dimensions are in mm.

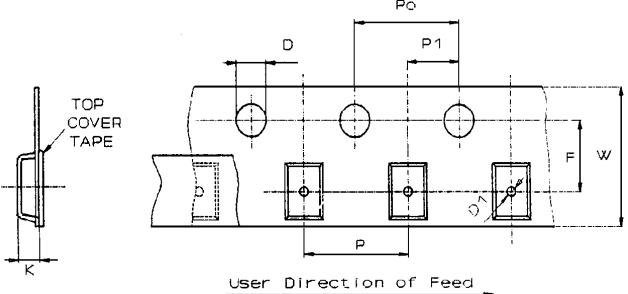

Information furnished is believed to be accurate and reliable. However, STMicroelectronics assumes no responsibility for the consequences of use of such information nor for any infringement of patents or other rights of third parties which may result from its use. No license is granted by implication or otherwise under any patent or patent rights of STMicroelectronics. Specifications mentioned in this publication are subject to change without notice. This publication supersedes and replaces all information previously supplied. STMicroelectronics products are not authorized for use as critical components in life support devices or systems without express written approval of STMicroelectronics. The ST logo is a trademark of STMicroelectronics

© 2003 STMicroelectronics - Printed in ITALY- All Rights Reserved.

STMicroelectronics GROUP OF COMPANIES

Australia - Brazil - Canada - China - Finland - France - Germany - Hong Kong - India - Israel - Italy - Japan - Malaysia -  
Malta - Morocco - Singapore - Spain - Sweden - Switzerland - United Kingdom - U.S.A.

<http://www.st.com>